

**Layla**<sup>®</sup> by **eCHO**<sup>®</sup>

**Owner's Manual Version 2.2 for Mac**

Layla is designed and manufactured in the U.S. by Echo Corporation

## **Important Safety Instructions**

- 1. Read Instructions** - Be sure to read all of the safety and operating instructions before operating this product.
- 2. Retain Instructions** - The safety instructions and owner's manual should be retained for future reference.
- 3. Heed Warnings** - All warnings on Layla and in the Owner's Manual should be followed.
- 4. Follow Instructions** - All operating and use instructions should be followed.
- 5. Moisture** - Water and moisture are detrimental to the continued good health of Layla. Do not install or operate Layla near sources of water or moisture such as sinks, damp basements, leaky roofs, etc.
- 6. Heat** - Layla should be situated away from sources of heat such as heaters or radiators.
- 7. Power Sources** - This unit should be operated only from the type of power source indicated in this documentation or on Layla. If you are unsure about the type of power at your location, contact your local power company.
- 8. Grounding** - Precautions should be taken so that the grounding capabilities of the Layla are not undermined. This equipment is provided with a cord having an equipment grounding conductor and grounding plug. This plug must be plugged into an outlet that is properly installed and grounded in accordance with all local rules and ordinances. Do not modify the plug provided with the equipment. If the plug will not fit into your outlet, have a proper outlet installed by a qualified electrician.
- 9. Power Cord Protection** - Power supply cords should be routed so that they are unlikely to be walked on or pinched by items placed upon or against them. Pay particular attention to protecting the plugs, outlets, and the point at which the cord exits Layla.

**10. Servicing** - Do not attempt to service this unit yourself, as opening the case will expose you to hazardous voltage or other dangers. All servicing should be referred to qualified service personnel.

**11. Damage Requiring Service** - Unplug this unit and refer it to a qualified service technician when any of the following occur:

- a) Objects have fallen or liquid has spilled into the unit
- b) The product has been exposed to rain or water
- c) The product does not operate normally or when a marked change in performance is noticed
- d) The product has been dropped or damaged in any way

Sending in your registration card – or registering online at <http://www.echoaudio.com/register.html> - allows us to register key information so that we may handle problems faster and inform you of advance information on upgrades and other news. Thanks in advance for filling out your registration card and sending it to us. We hope you enjoy your Echo product.

## Limited Warranty

Echo Corporation warrants this product, when purchased at an Authorized Echo Dealer in the United States of America, to be free of defects in materials and manufacturing workmanship for a period of one year from the date of original purchase. During the warranty period Echo shall, at its option, either repair or replace any product that proves to be defective upon inspection by Echo. Final determination of warranty coverage lies solely with Echo. Echo reserves the right to update any unit returned for repair, and reserves the right to change or improve the design of the product at any time without notice.

This is your sole warranty. Echo does not authorize any third party, including any dealer or sales representative, to assume any liability on behalf of Echo or to make any warranty for Echo.

Service and repairs of Echo products are to be performed only at the factory (see below) unless otherwise authorized in advance by the Echo Service Department. Unauthorized service, repair or modification will void this warranty.

### To obtain factory service:

Contact Echo Corporation at (805) 684-4593, 9AM to 5PM Monday through Friday (Pacific Time). If necessary, you will be given a return authorization number. Products returned without an RA number will be refused. Echo may, at its option, require proof of the original date of purchase in the form of a dated copy of the original authorized dealer's invoice or sales receipt.

Pack the product in its original shipping carton and attach a description of the problem along with your name and a phone number where Echo can contact you if necessary. Ship the product insured and freight prepaid to:

**Echo Corporation  
6460 Via Real  
Carpinteria, CA 93013**

## DISCLAIMER AND LIMITATION OF WARRANTY

Echo Corporation makes no other warranties, express, implied, or otherwise, regarding Echo products, and specifically disclaims any warranty for merchantability or fitness for a particular purpose. The exclusion of implied warranties is not permitted in some states and the exclusions specified herein may not apply to you. This warranty provides you with specific legal rights. There may be other rights that you have which vary from state to state.

In no event will Echo Corporation be liable for any lost profits, or for any consequential, direct or indirect damages, however caused and on any theory of liability, arising from this warranty and sale.

©1999 by Echo Corporation  
6460 Via Real  
Carpinteria, CA 93013

Echo® is a registered trademark of Echo Corporation  
Layla®, Gina®, and Darla® are trademarks of Echo Corporation  
Windows®, Windows '95®, Windows '98®, and Windows NT® are registered trademarks of Microsoft, Inc.  
Macintosh®, Power Mac®, G3® and Power PC® are registered trademarks of Apple Computer, Inc.

# Table of Contents

---

<b>Introduction</b>	6
What You Should Have Received in the Layla Box	6
System Requirements	6
<b>Layla Installation</b>	7
Checking your Macintosh	7
Install 3 <sup>rd</sup> Party Multitrack Software	7
Configuring your Macintosh System	8
Installing the Layla Hardware	13
Connecting to Layla's Rack-mount Interface	16
Running the Echo Card Installer	21
Layla Audio Input & Output Devices	23
Custom Install: Additional ASIO and OMS Drivers	24
ASIO Driver Configuration	25
OMS Setup	25
<b>The Echo Console</b>	28
The Options Menu	29
Console Controls	31
Monitor Controls	32
Adjusting Record Levels	33
Setting Clock Sources and Destinations	33
Synchronizing Multiple Devices	34
<b>Contacting Customer Service</b>	37
<b>Appendix A: Introduction to Digital Audio</b>	38
<b>Appendix B: Specifications</b>	42
<b>Index</b>	43

# Introduction

Thank you for choosing the Layla 20-bit Multitrack Digital Audio Recorder. We think you'll find Layla to be an extremely flexible, high-performance tool for your computer-based hard disk recording system.

## What You Should Have Received in the Layla Box

When you opened the Layla box, you should have found the following:

- A Layla PCI card wrapped in an anti-static cover
- A Layla rack-mount audio interface box
- A Layla digital control connector cable
- A compact disc containing the Macintosh Installer and demo versions of digital audio recording, editing, and processing software from a variety of manufacturers.
- The Layla Owner's Manual
- Four adhesive backed rubber feet and four mounting screws with collars.

## System Requirements

In order to use Layla you'll need the following:

- An Apple brand Macintosh computer with a 604 or higher processor (G3 highly recommended). Our latest drivers now support the Apple Macintosh 1999 G3's (Yosemite). We will not be able to supply technical support for any non-Apple brand Macintosh clone computers.
- A fast, high-capacity IDE or SCSI hard disk drive
- An audio software program that uses ASIO: Cubase VST, VisionDSP, etc.
- Peripheral audio equipment, such as a mixer, power amplifier, DAT recorder, musical instruments, cables, etc.

# Layla Installation

Complete Layla installation consists of performing a system check, installing any multitrack recording software, configuring your Macintosh for multitrack audio, installing the Layla PCI card, connecting the rack-mount audio interface to the card, running Install Echo Card and, if necessary, installing additional ASIO and OMS drivers.

## Checking your Macintosh

1. **Do you have enough Memory?** With your mouse select **Apple – About this computer**. Look at the amount of **Built-in Memory** you have. You will need to have at least 64Mb to use Layla in your computer. It is highly recommended that you have more.
2. **Is your Processor fast enough?** Select **Apple System Profiler** from the **Apple** menu. Look at the section entitled **Hardware overview** and see what kind of processor you have. If it's a PowerPC 604 or higher, then you can use the Layla.
3. **Do you have an open PCI slot?** Make sure that you have an open PCI slot in your Mac. If you don't know offhand, you will have to open up the Mac and look. Make sure you shut down the Mac and unplug the power cable before you open it. If you see an open PCI slot, then you're OK.

If your system checks out OK, it's time to move on to the next phase of installation.

## Install 3<sup>rd</sup> Party Multitrack Software

If you haven't already, we recommend that you install any 3<sup>rd</sup> party software now. This is not essential, but it will help when installing the Extensions and drivers for Layla later.

## Configuring your Macintosh System

1. **Check your Boot Disk.** Most people only have one OS on their Mac, so they can ignore this section. If you have multiple hard drives with separate OSs in your Mac, then you will have to install the Layla software separately for each OS. To check your boot disk, go to **Apple – Control Panels – Startup Disk**. Make sure that the drive you want to boot from is highlighted. If you have changed this selection, you will have to restart for it to take affect.

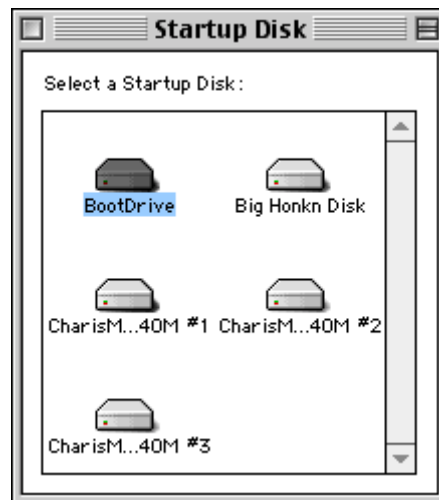

2. **Turn Virtual Memory Off. Turn RAM Disk Off.** Go to **Apple – Control Panels – Memory**. Where it says Virtual Memory, click **Off**. While you're here, make sure that RAM Disk is also **Off**. These settings are necessary for the Layla software to work properly.

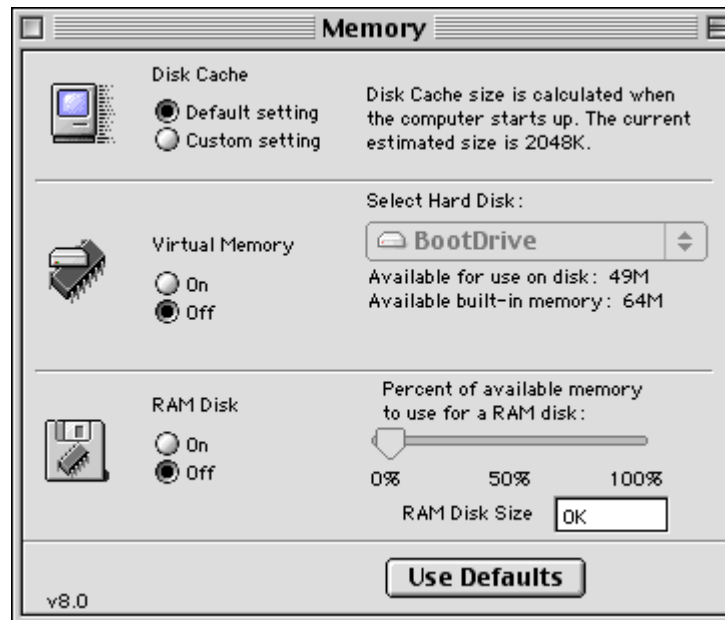

3. **Make Alias for Sound Control Panel.** Now you are going to install a helpful sound utility. Double click on your boot disk (if you have more than one hard drive and don't know which one this is, see #1 above). Now open the **Apple Extras** folder, and then open the **Sound Control Panel** folder. Here you will see a program called **Sound**. Highlight it by clicking on it once. Now select **File – Make Alias**, and then do it a second time. Now drag both of the aliases to your desktop. Go back to the boot disk and open **System Folder**, and find the folder called **Control Panels**. Drag one of the aliases into the **Control Panels** folder. Now you can access the **Sound Control panel** from your desktop or from the **Apple – Control Panels** menu.

4. **Set Sound In and Sound Out to Built-in.** Open the **Sound Control Panel**. You can do this by double clicking the alias you just created and put on your desktop. Select **Sound In** from the drop down menu. Highlight **Built-in** by clicking on it. Now select **Sound Out** from the drop down menu. Highlight **Built-in** by clicking on it. Both of these settings may have already been set to Built-in, but it's good to make sure.

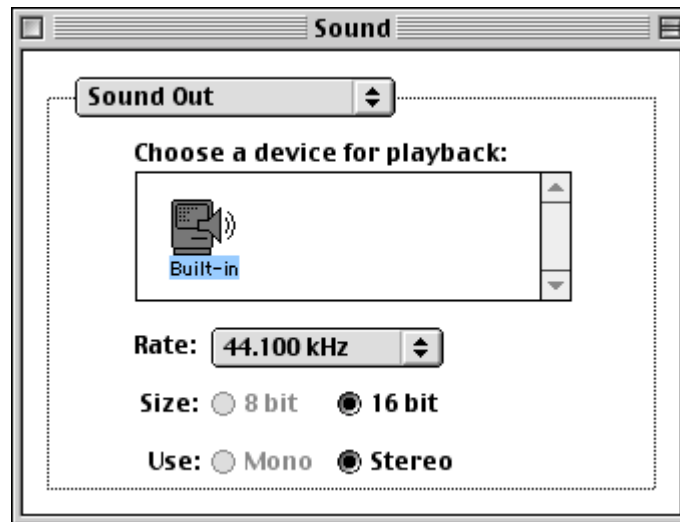

5. **Turn Off Folder/Menu Sounds.** This is optional, but highly recommended. If you leave these on, then some audio programs (like Cubase VST) may not function as well as they could. Go to **Apple – Control Panels – Appearance**. Click the **Sound** tab. In the **Sound Track** menu select **None**. If you had a sound scheme selected before, you would have heard sounds accompanying every mouse click and drag. Now you should hear nothing.

6. **Mute/Turn down Built-in Volume.** This is also optional, but highly recommended. If you leave the Built-in volume on, the alert sounds could interfere with a live recording using an ASIO program. Open the **Sound Control Panel** by double clicking the alias on your desktop (The one you created in step 3). Select **Volumes** from the drop down menu. Move the slider for **Built-in** to the bottom, and make sure there is a check in the **Mute** box.

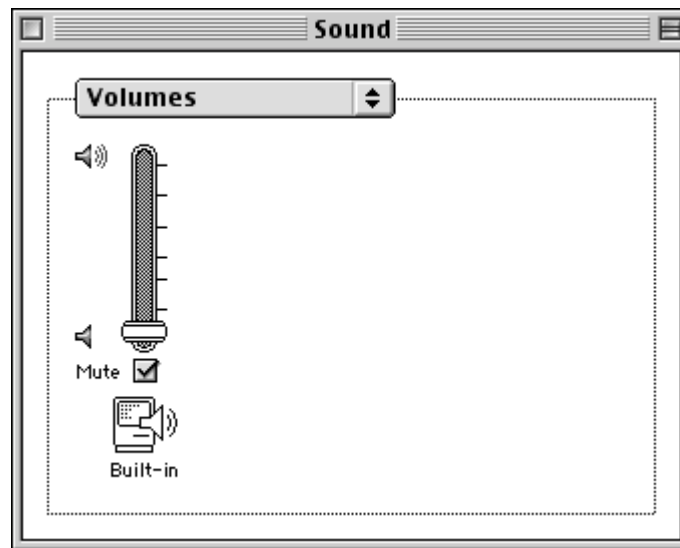

7. **Create an Audio Extensions Set.** You need a separate Extensions Set with certain Extensions disabled so that your audio program can perform at its best with the Layla system. First, select **Apple – Control Panels – Extensions Manager**, and click the **Duplicate Set...** button. Type in a name (like Audio Settings), and click **OK**. Now scroll down the list of Extensions and disable all of them that have to do with networking, printing, and any that say OpenTransport or OpenTpt. You disable an Extension by clicking the corresponding On/Off checkbox so that it is empty (meaning Off). Once you are done, click the **Restart** button and your Mac will restart using your new Audio Extensions Set.

If you ever want to switch back to your previous Extensions Set, go to the **Extensions Manager**, select it from the **Selected Set** drop down menu, and click **Restart**. When your Mac restarts, you will now be able to use any printers or networking functionality you had before you started. When you want to use your Audio program again, just select the Audio Extensions Set and restart.



## Installing the Layla Hardware

Once you have checked your system requirements, verified that there are no problems with your system, installed any 3<sup>rd</sup> party audio software, and have configured your Macintosh for multitrack audio, it is time to install Layla into your computer. Please refer to the section in your Mac manual for installing a PCI card.

***IMPORTANT - Unplug your computer and detach all peripherals before proceeding with the following steps.***

- 1. Remove your computer's cover.** This operation differs from computer to computer. Refer to your computer's manual for a further explanation of this step if necessary.
- 2. Select the slot into which you will install the Layla card.** You may use any of the available PCI slots in your computer for Layla. Remove the bracket covering the expansion slot where you would like to install Layla. If there was a screw for the bracket, put it in a safe place, as you will need it later to complete installation.
- 3. Insure that you have fully discharged all static electricity from your body before handling the Layla card.** This can be done through the use of a grounding strap or, more simply, by touching your bare hand to the metal casing of the computer's power supply. (For this latter method to work, the computer must be plugged in, though not turned on. After you've discharged your static, unplug the computer before proceeding to the next step.)
- 4. Insert card into slot.** Remove the Layla card from its protective anti-static bag. Handle the card carefully by its edges and insert it into the selected expansion slot. Insure that the card's edge connector (the protruding edge with the gold leads) is seated firmly into the slot. Centering the card over the slot and using a gentle rocking motion while pushing downward into the slot generally works well. Be careful not to force the card into the slot, or bend or twist it while it is being inserted, as this could result in the card being damaged.

5. **Secure card to computer.** If there was one, use the screw removed earlier from the protective backplate to attach the metal bracket at the back of the Layla card to the computer's rear panel. *On many Macs the locking mechanisms used to hold down the PCI cards cause difficulties properly seating the cards.* We recommend checking the card and making sure it is well seated and liable to stay that way. If the card is loose or being pushed around by the locking Mechanism, we recommend loosening the hex screws that hold the back-plane of the card to the Mac, that thin metal piece that sits against the case of your computer. Another option, if that piece needs a little more play, gently bend it back. Some users have broken the plastic that comes with their Mac to solve this problem. However, due to Mac warranty issues, we are not able to recommend this approach.
  
6. **Replace the computer's cover and secure it.** Please refer to your Mac manual for instructions. Reattach its power supply cord and reconnect any peripherals that you may have removed prior to beginning the Layla installation.
  
7. **Locate the Layla rack-mount interface and the 25-pin audio connector cable.** Securely mount the interface into your equipment rack. If you will not be mounting the box in a rack, remove the backing from the four rubber feet and place one in each bottom corner of the interface unit. Then be sure to locate the rack-mount box in a secure location.

Plug one end of the cable into the 25-pin connector on the Layla card that now protrudes through the back panel of your computer, and secure the cable using the built-in screws located on both sides of the connector. Attach the other end of the cable to the rear of the interface and fasten the cable securely with the screws.

*Caution: Never connect the rack-mount interface to the computer while either the interface or your computer is turned on.*

8. **You can now attach external audio devices to the rack-mount box.** Layla can accommodate eight analog input signals and can generate ten independent analog output signals. In addition, Layla provides word clock/superclock sync, MIDI in/out/through, and stereo S/PDIF digital input and output. Additional information on attaching external devices to Layla may be found in the **Connecting to Layla's Rack-mount Interface**

section. (NOTE: When connecting devices to the S/PDIF jacks on Layla, do not use standard RCA audio cables. For reliable S/PDIF operation, 75ohm coaxial video cables are recommended).

All of the analog and digital inputs and outputs on Layla are simultaneously active, allowing you to record up to 10 channels of audio (eight analog and two digital) while playing back twelve channels (ten analog and two digital).

## Connecting to Layla’s Rack-mount Interface

The back panel of Layla’s rack-mount interface contains a wide variety of connections that allow great flexibility in the operation of Layla. To achieve the optimal performance with Layla, it is critical that the appropriate cabling and connectors are used.

### Analog Inputs and Outputs

Layla has eight analog inputs and ten analog outputs on the back panel, as well as two inputs on the front (the two inputs on the front are alternate connectors for channels 7 and 8 on the back of Layla. When you plug into the front panel inputs, the corresponding back panel inputs are disabled). These connections can accept balanced or unbalanced signals.

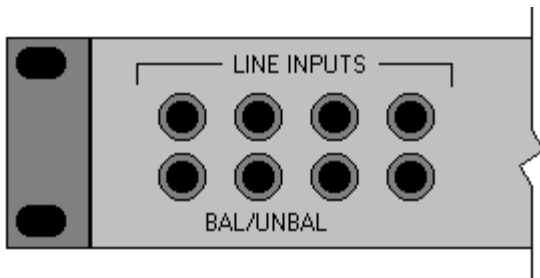

An unbalanced signal contains two components, a ground signal and a “hot” or active signal. A balanced signal contains these two components with the addition of a second active channel that is 180 degrees out of phase from the primary signal. In this way, a balanced signal can eliminate any noise that may be introduced into the audio signal during transmission. The connectors used for the analog inputs and outputs on Layla are TRS (tip, ring sleeve).

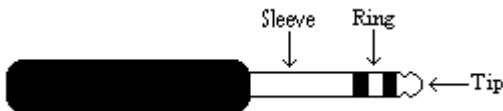

The three sections of a TRS connector are used to transmit the three components of a balanced signal. Layla will also accommodate the two conductor unbalanced style connector.

## The Host Connector

Next to the analog inputs and outputs is a connector labeled **HOST**. This connector is known as a DB-25, and is commonly used on PCs for the printer port. It is the point at which the audio interface connects to the Layla PCI card inside your computer.

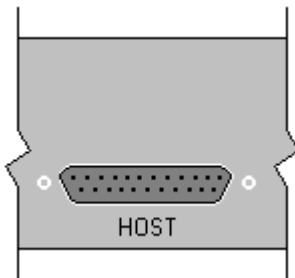

A cable was supplied with your Layla for this purpose. This cable is manufactured to certain specifications, and if necessary, should only be replaced with a cable that meets specification IEEE-1284. Layla is designed for use with cables of up to 15 feet in length. Cables in excess of 15 feet may cause loss of data and/or diminished system performance.

## S/PDIF

Next to the **Host** connector is a pair of connectors labeled **S/PDIF in** and **out**. S/PDIF is used to transmit digital data among digital audio devices. S/PDIF data can use the full 24-bit sample width used internally on Layla.

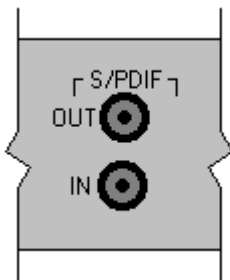

When connecting devices to the S/PDIF jacks on Layla, the use of standard RCA audio cables is not recommended. For reliable S/PDIF operation, 75ohm coaxial (RG59) video cables are recommended.

## Word Clock

Next to the S/PDIF ports are the **Word Clock** connectors. These connectors allow you to synchronize one Layla to another Layla or to other digital audio devices. In addition to a standard word clock signal, these connectors also allow you to synchronize using the superclock format, which is 256x the selected sample rate.

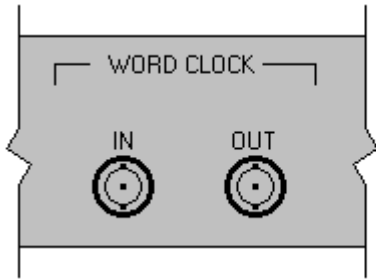

The word clock I/O uses a BNC connector. As with the S/PDIF I/O, a shielded 75 ohm (RG-59) coaxial video cable should be used. BNC connectors are widely used in the electronics industry for both video and computer networking. However computer networks use 50 ohm (RG-58) coaxial cables and not the 75 ohm (RG-59) cable used by video. For reliable word clock operation, use only video cables with Layla.

## MIDI

The last set of connections to the Layla interface is for MIDI. The MIDI ports can be used for receiving MIDI time code (MTC), sending MIDI signals from your digital audio/MIDI sequencing software to external sound modules, etc.

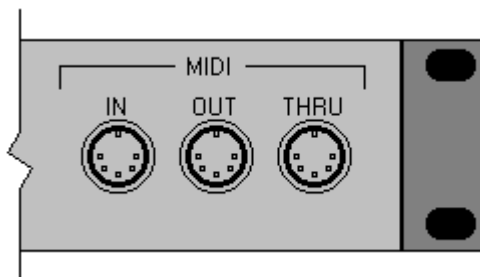

MIDI cabling is highly standardized and widely available.

The diagrams on the following two pages illustrate sample configurations using Layla and external audio equipment:

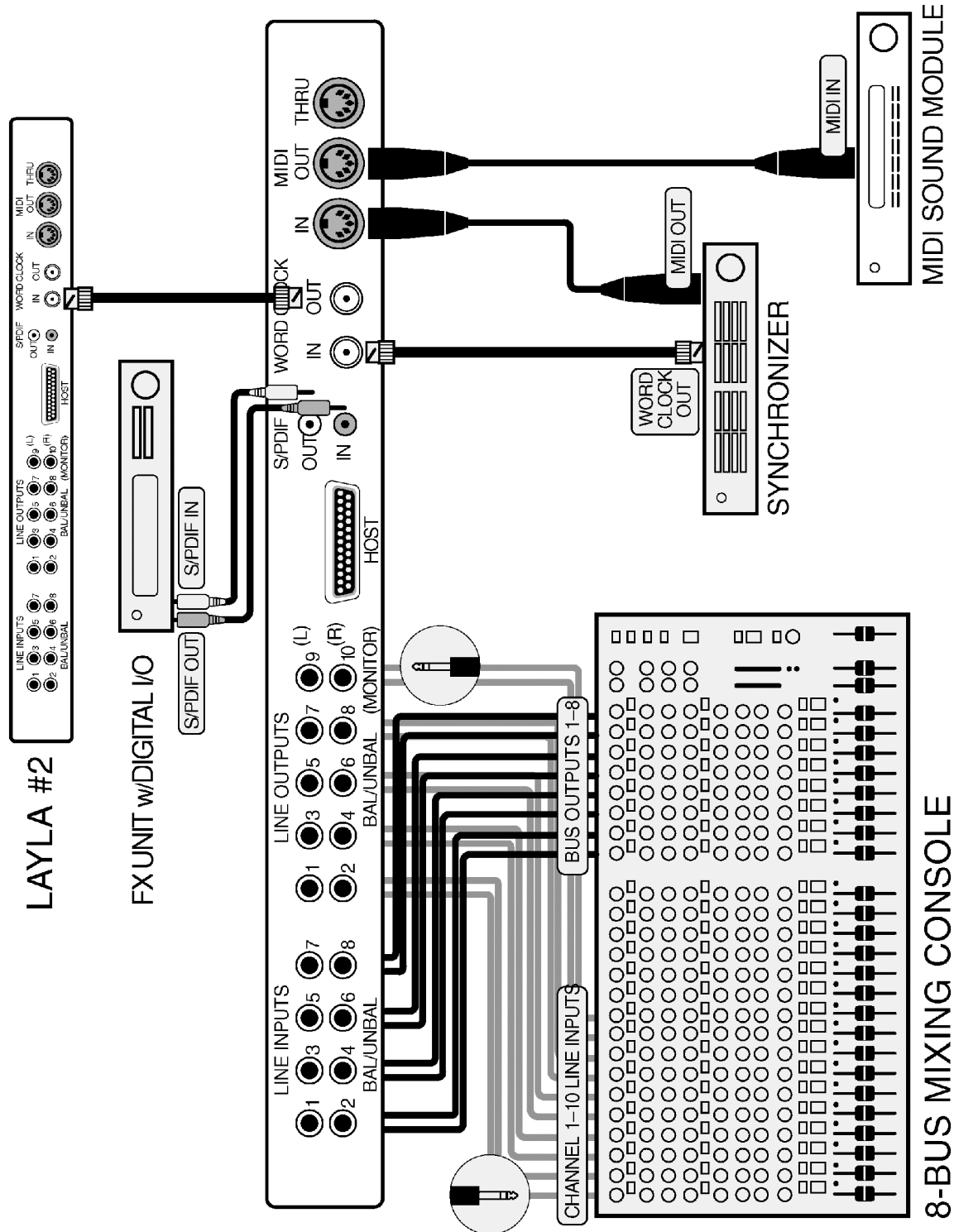



## Running the Echo Card Installer

Now that you have completed the hardware installation, you need to run the installer for the Layla to interact properly with the MacOS and your audio recording application.

What the installer does:

- Deletes the EchoCard Extension if a previous version exists
- Deletes the EchoConsole if a previous version exists
- Copies the Layla Echo Card extension to the system folder
- Creates the Echo Card Folder and puts the Echo Console in it
- Copies the Layla ASIO Driver
- Copies the Layla OMS Driver

Insert the Layla Mac Installation CD into your CD-ROM drive. Double click the icon called **Install Echo Card**. Read the **Release Notes** that appear so that you will be aware of any important updates. If you want to read it later, you will find a **Read Me** file in the Echo Card Folder after installation. After you're done with the Release Notes, click **Continue**.

You will see a message saying '**Preparing to install...**' and the installer may take several minutes before it continues, so please be patient. After a while you will see a new box that says **Easy Install**. You will want to keep this setting and press the **Install** button.



Now select where you want the **Echo Card Folder** to be installed. The default is to your desktop. You will get a message about restarting after installation – Press **Yes** to continue.

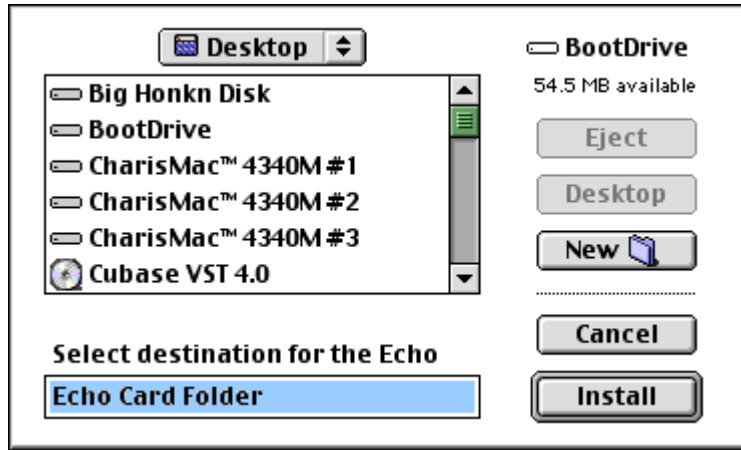

Now you will see the installer working, and then you will be asked which ASIO folder you want to install the **Layla ASIO Driver** to. If you have more than one audio program that uses ASIO, then you will have to select one folder, and then come back later to install the ASIO driver to your other program(s). You will find instructions on how to do this in a following section. Once you have selected a folder, press the **Select** button.

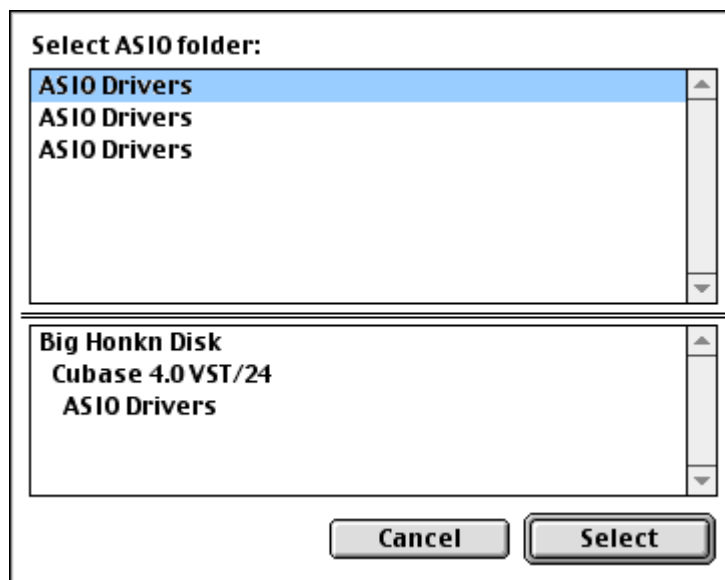

You should now see a message saying '**Installation was successful.**' Press **Restart** and make sure the power to the Layla rack mount box is on. It may be a good idea to turn down your mixer at this point, as there can be some noise when restarting.

During restart, the red Echo Extensions Icon should appear on the lower left corner with your other extensions. If you don't see the red icon, check to see if there is a space for that icon. Some video cards for the Mac have a problem where they repaint the screen, hiding our little icon from sight. However, the space will still be there for the icon. This does not affect the performance of the Layla system. There should be one icon for each Echo Card in your computer. If this is not the case, then the card probably isn't being recognized by your Mac. Shut down your Mac, and make sure the card is seated properly in the PCI slot. Go back to the hardware installation section for instructions on how to do this.

After the system has booted, go into **Sound Control Panel** and make sure that the card is there. You can do this by double clicking the handy alias you created earlier. Look in Sound In and Sound Out. If you don't see it here, you may not have installed the card properly.

## **Layla Audio Input & Output Devices**

Now do a quick sound check. First, go to the **Echo Card Folder** you installed earlier. Open it and double click the **Echo Console** icon.

### **\*\*\*WARNING - IMPORTANT\*\*\***

This will set the Layla hardware to unity gain. You will need to do this after every restart or else the Layla volume levels will be extremely loud. Don't hurt your ears!! Now go into **Sound Control Panel – Sound Out** and select Layla. Now select **Alert Sounds**. Make sure the volume levels aren't too high, and click a sound. If you have the Layla hardware set up properly to a set of speakers, then you should hear the sound. If you don't, then double check your cables and try again. If you hear a sound then you have succeeded in installing Layla!! Give yourself a pat on the back.

Important - remember to switch **Sound Out** back to Built-In!!!

## Custom Install: Additional ASIO and OMS Drivers

If you have several audio programs that use ASIO, then you will need to install the **Layla ASIO Driver** to the corresponding ASIO folder for each program. You should have already installed the **Layla ASIO Driver** to one of these programs as part of the installation process above. Open the Layla Mac Install CD and start the **Install Echo Card** program just like you did earlier. Follow the instructions from before until you get to the part with the **Easy Install**. Remember, you may have to wait a while. Click on the box that reads **Easy Install**, and select **Custom Install**.

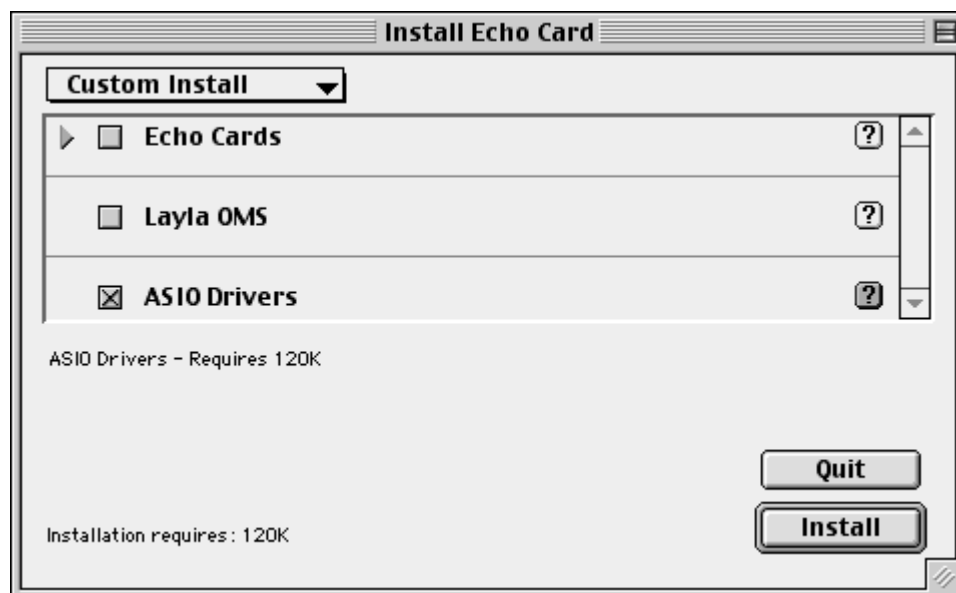

Now you should see several installation options. Depending on what you want to install, click the appropriate checkbox or boxes. If you just want to install the ASIO Drivers, then just click that checkbox and leave the other ones empty. Press **Install**. You will now see the **Select ASIO folder** window. You can only select one folder at a time, so if you have more than two audio programs that use ASIO you will have to come back and do this again. After you have chosen a folder, press **Select**. If you want to install some more Layla drivers click **Continue**. If you are done, click **Quit**. Just one more step and you'll be making music with ASIO.

## ASIO Driver Configuration

You have now finished installing the **Layla ASIO Driver** to all of your audio programs that use ASIO. You now need to select the **Layla ASIO Driver** from within your audio program. Please refer to your audio program manual for instructions on how to do this.

## OMS Setup

If you have OMS for MIDI, then you will need to run OMS Setup to allow your audio programs to use the Layla OMS Driver. Please keep in mind that this section is just an aid to the instructions in your OMS manual. First, you will need to find the **Opcode** folder on your hard drive where you installed OMS. Open it and then open the folder called **OMS Applications**. Find **OMS Setup** and double click it. Go to the **File** menu and click **New Studio Setup**.



Click **OK**. A new window will come up. Click **Search**. OMS will search for any new equipment, and then you should see Layla recognized in a window like this:

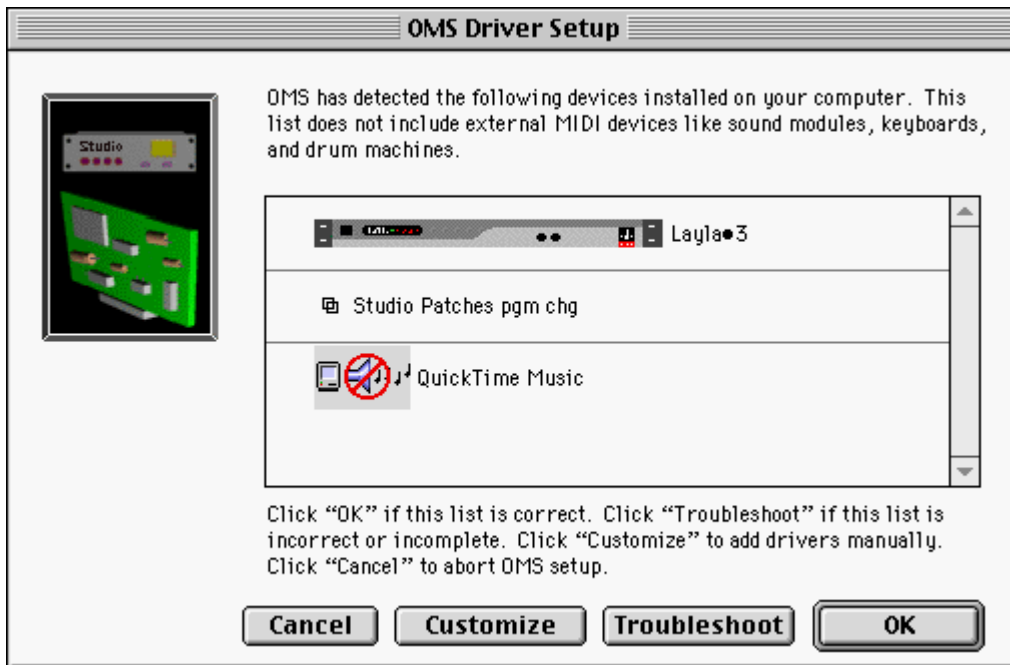

The **OMS Driver Setup** window recognizes MIDI hardware drivers in your system. If there is something missing, then refer to your OMS manual and follow the instructions. If everything is OK, then click **OK**. Now you will see the **OMS MIDI Device Setup** window.

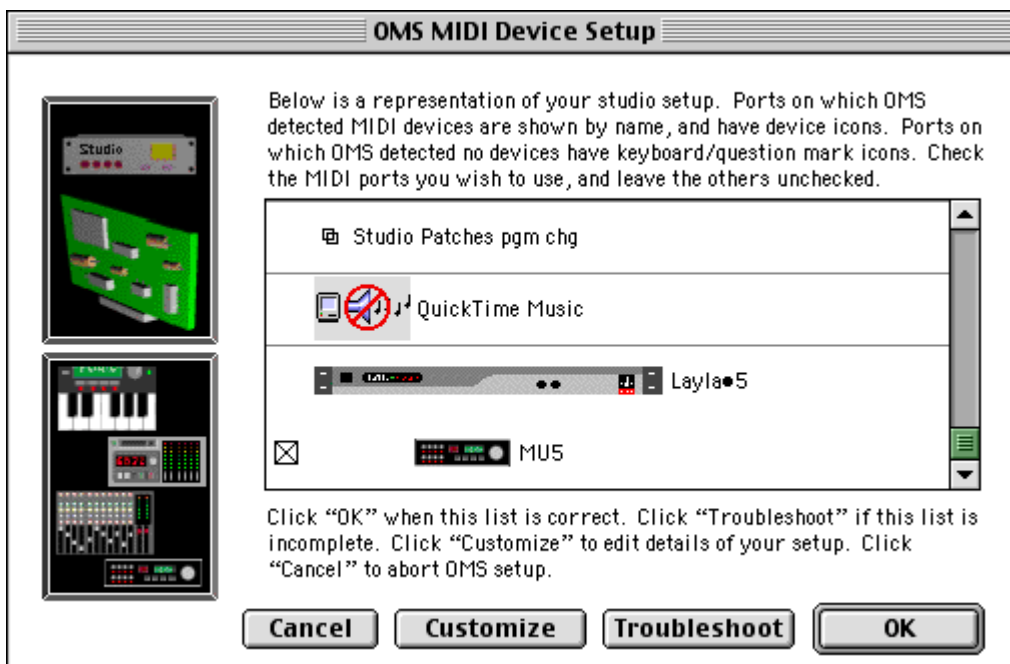

This window recognizes any MIDI devices (like synthesizers) currently attached to your system through your MIDI hardware (like Layla). In the example you can see that an MU5 Tone Generator is attached to the system through Layla. Scroll down and make sure everything is OK. If there is a problem, or you need to edit your setup, then refer to your OMS manual for instructions. If all is well, click **OK**. Now you will be asked to save the new studio setup. You can overwrite your old setup with the same name or create a new one. Click **Save** when you're done and you'll see a window displaying your new setup. If you want to test your new setup, go to the **Studio** menu and click **Test Studio**.

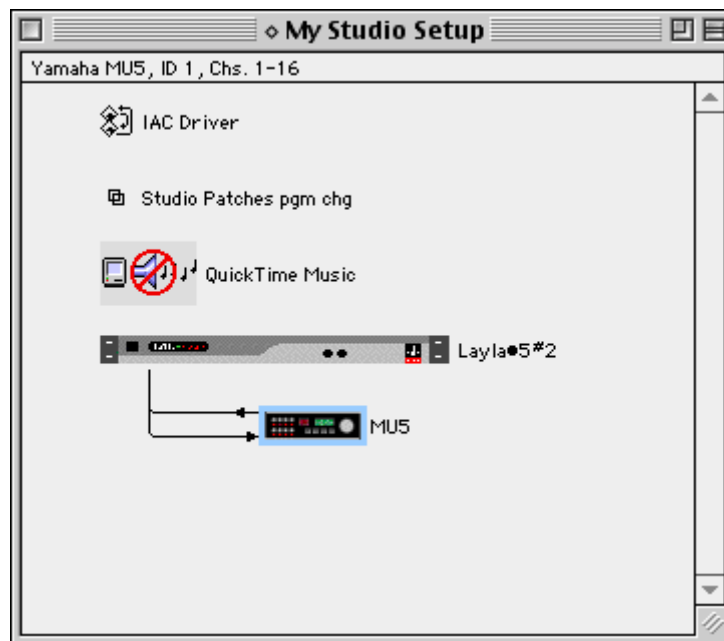

Your mouse pointer will turn into a musical note. In the Setup window, click on a tone generator or synth. If it's turned on and hooked up properly, then you should hear a sound coming out of the MIDI devices outputs. If you do, then you're all done. We hope you enjoy the Layla multitrack digital audio recording system.

This completes the installation of the Layla hardware and software.

# The Echo Console

Included with your Layla is a “virtual control surface” application called The Echo Console. The Console allows you to control the audio I/O and clocking functions of Layla, and it brings these controls to a single easy-to-use location. From the Console you can control input levels, select synchronization clocks, and adjust input monitoring.

The Echo Console software can be found in the **Echo Card Folder** that was created during installation. Double clicking on the **Echo Console** icon will activate the console program. It should look like this:

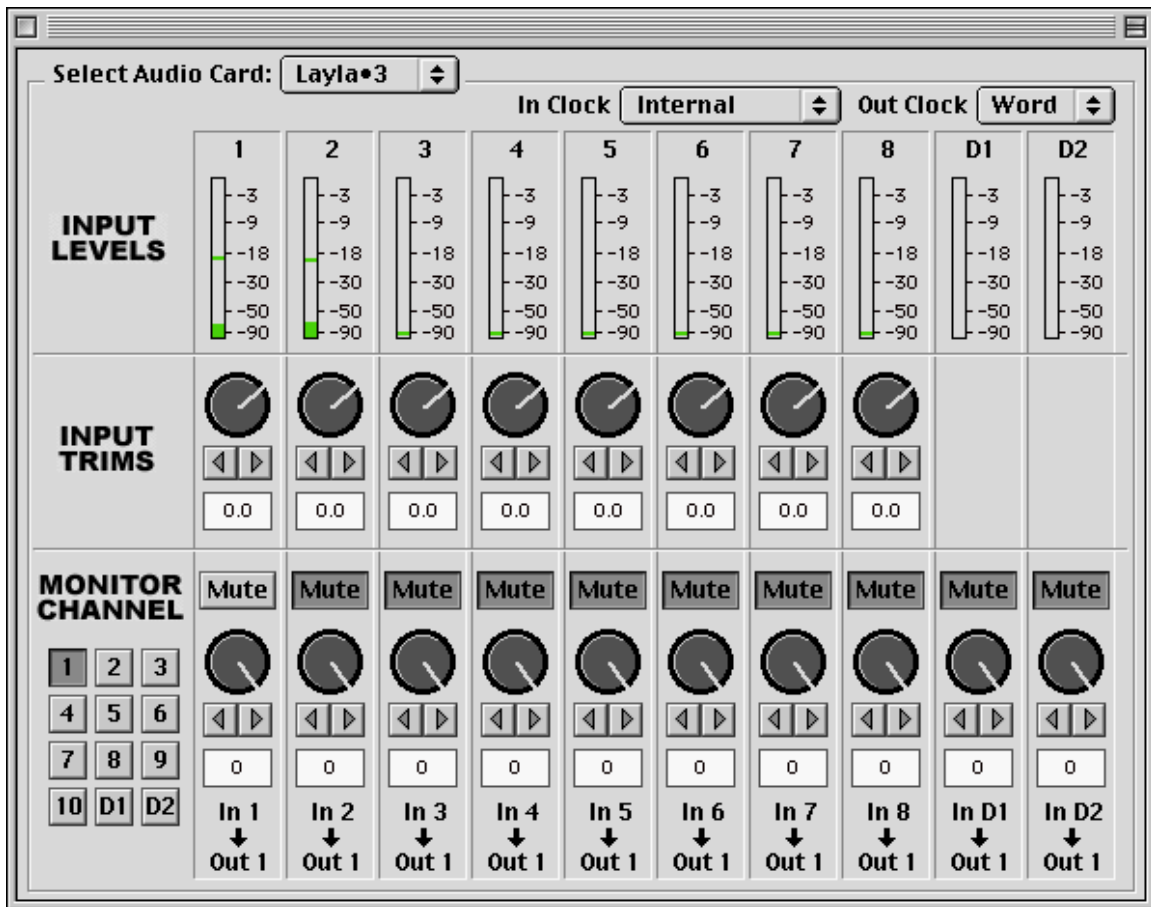

The console functions are grouped into three areas: clock selection (at the very top), input levels and trims (occupying the top half), and monitor channels (at the very bottom).

## The Options Menu

The first option, **General...**, is greyed out because it is not currently supported. It will be available in a future release.

The second and third options are **Set Input +4/-10...** and **Set Output +4/-10...** These options produce two similar windows that (except for the words input/output) look like this:

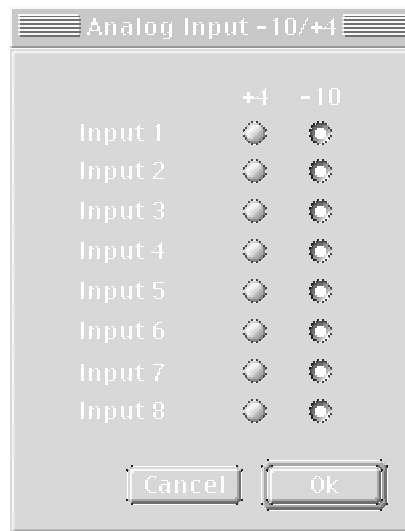

The **Analog Input** window lets you choose how the gain level is displayed, whereas the **Analog Output** window lets you choose the actual level of gain output for each of the analog outputs on Layla. In this way, devices with differing nominal operating levels are easily accommodated, and their input gain levels properly displayed on the Echo Console.

The fourth option is **MTC Settings...** and the window looks like this:

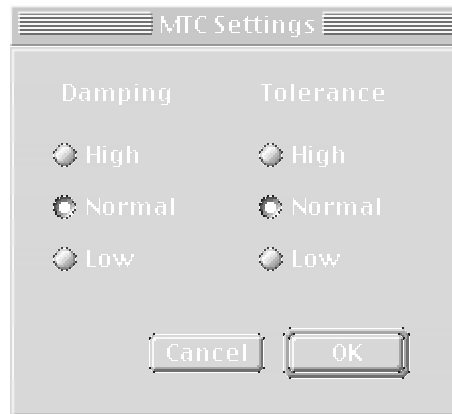

The MTC refers to MIDI Time Code. Because of the somewhat coarse resolution of MIDI Time Code, and its ability to exhibit “wow and flutter” (fluctuations in timing and consistency), the sync signal may sometimes stray from optimal. The Layla driver will automatically correct for these inconsistencies. When and how these corrections are made is configurable.

The **Tolerance** setting lets you select how far you want to allow the synchronization to stray before a correction is made. Many times, if left alone, the sync may correct itself by first straying in one direction and then going back the other way. If the tolerance is set too low, Layla will correct the synchronization too frequently. This produces frequent jumps to correct the clock, introducing jitter. If the tolerance is too high, the synchronization will shift too far before a correction is made, which will also yield unsatisfactory results.

The **Damping** setting lets you configure how quickly the corrections described above take place. Once Layla has determined that a correction is needed, a low damping level will effect the correction rapidly. A high level of damping causes the correction to occur in a more gradual nature.

If you feel that a change is needed in the defaults for these settings because of poor MTC synchronization, it is generally wise to adjust the **Tolerance** setting first. Use the **Damping** adjustment if you are unable to obtain satisfactory results with the **Tolerance** setting.

The fifth and sixth options are **S/PDIF Pro** and **S/PDIF Consumer**. Layla can transmit digital information in either of two modes, “professional” or “consumer.” The primary difference between the two is in the implementation of the SCMS copy-protection bit, which, in the consumer format, prevents the user from making digital copies of a digital copy.

Layla’s S/PDIF output defaults to the Consumer mode. If you are recording from Layla into a professional DAT deck, the deck may not be able to recognize the signal until you switch Layla’s output to Professional mode.

These options allow you to select which mode Layla transmits. In the options menu that appears you’ll see a check next to **S/PDIF Pro** or **S/PDIF Consumer**. The mode that is checked is the current one. Select the appropriate mode for your DAT (if you don’t know which one to use and are having difficulties, simply try the one that is not currently checked).

Important note: Layla never transmits the SCMS bit, regardless of which mode is selected.

## Console Controls

Let’s take a look at the control surface. The **Input Levels** are located in the upper portion of the console surface.

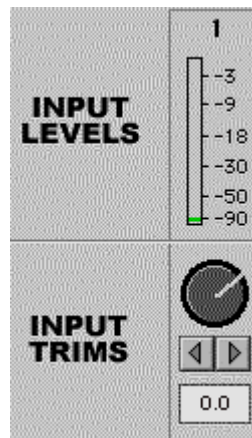

Directly below the **Input Levels** are the **Input Trims**. For each level meter there is a knob below it for input gain attenuation. Below every knob is a display that shows the currently selected level of attenuation or gain. You

can change the gain level by clicking in the display and typing, by clicking the arrows, or by click holding the knob and dragging right or left. You can also zero the level by holding the **Command** button on your keyboard and clicking the knob.

## Monitor Controls

Below the **Input Levels** and **Input Trims** are the **Monitor Channel** controls. The input monitor controls allow you to monitor the record input signal via any of the available outputs on your Layla. Each input channel has a corresponding monitor output channel directly below it on the console. The monitor controls look and function similar to the controls for input. Note the addition of a **Mute** button to each channel. There is also a group of numbered buttons on the bottom left. These buttons allow you to select an output channel.

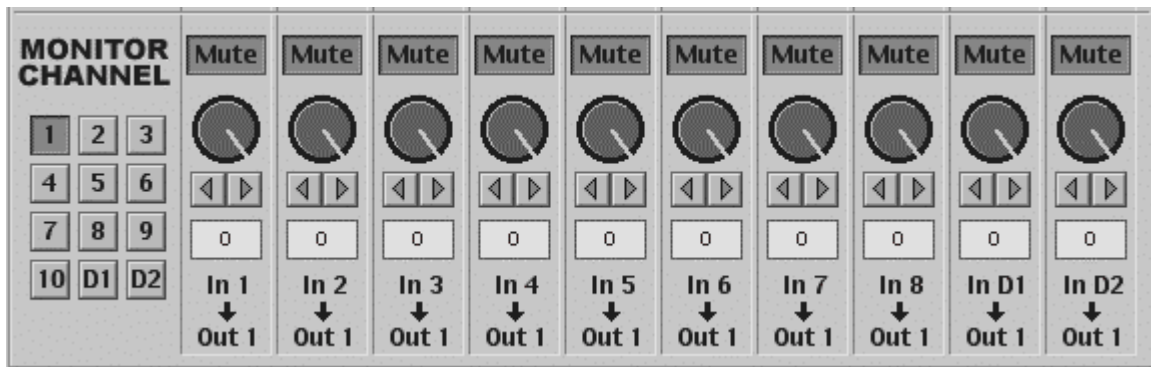

When button 1 is selected, all of the monitor controls affect what goes to output 1. Note that it says **Out 1** at the bottom of every channel. This will change according to whatever button is selected. The console will remember the changes you have made to each output even though you can only see one at a time. Take note that these controls are for the routing of audio signals from the Layla inputs to the Layla outputs only. The console does not control output that is generated by your computer (such as aiff files). That is controlled by whatever audio program(s) you may have.

Remember that all of the inputs are continuously monitored by all of the outputs at some level. The degree of attenuation (or muting) of that level is set by the monitor controls. The console program constantly maintains a level setting for each of the 120 monitor paths it controls. Clicking on an output selection button simply selects the settings that are displayed.

## Adjusting Record Levels

Layla's input volume adjustments are made in the digital domain. When you lower a volume slider, you are actually decreasing the number of available bits, thereby taking away from the potential dynamic range of the system. To avoid this, we suggest that whenever possible you leave the output sliders set to their maximum positions, and perform any necessary attenuation on your external mixer. When the playback volume controls in your audio program are set to maximum and the input signal approaches the maximum pre-clipping level, you can achieve the full 20-bit dynamic range of the system.

## Setting Clock Sources and Destinations

At the very top of the Console there are buttons that allow you to select the synchronization clocks that are used by Layla. The console program will sense which input clocking options are available, and automatically disable those that are unavailable. On the right are the output clock options.

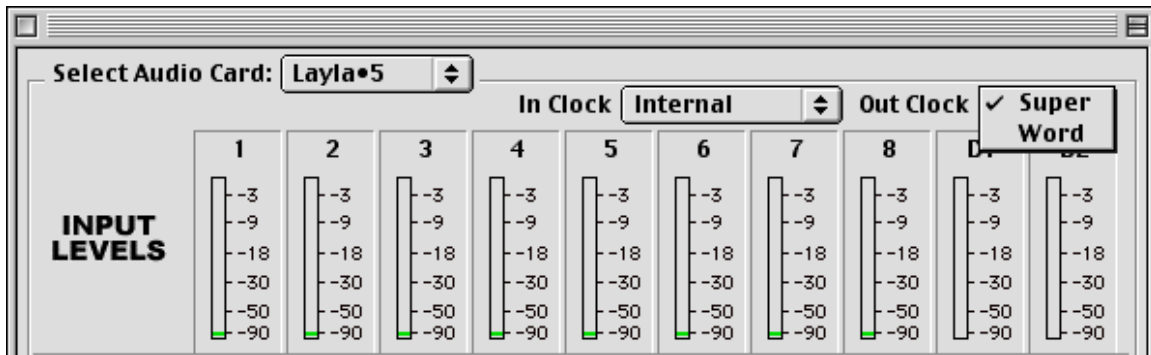

Here you can select from standard word clock or super clock (word clock x 256) output. To the left of the output clock selections are the input clock options. Depending on what external devices you have connected to Layla, you may have as many as five options here.

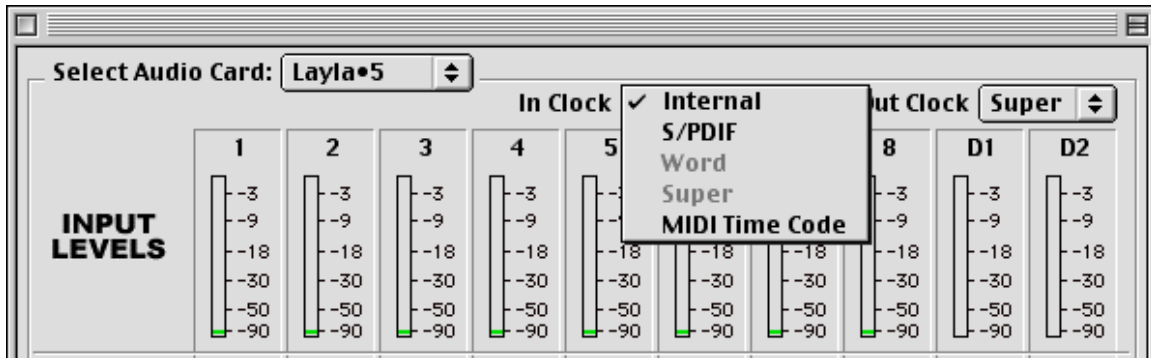

If you are unsure which clock synchronization selections are appropriate for your installation, be sure to read the next section, which deals with the types of clocks that Layla supports.

## Synchronizing Multiple Devices

Layla is designed to work alongside other audio equipment within a complete Macintosh system. If you are planning on using Layla with other audio equipment, please note the following:

The Layla Macintosh drivers included in this package currently do not support multiple Laylas within the same system. Future driver versions will support multiple Laylas in the same system. Fortunately, your new Layla will operate with Gina and Darla in the same system. Layla can also peacefully coexist with audio equipment from other manufacturers, but be aware that operating *alongside* another product is not the same as operating *with* it. In order for accurate synchronization to occur, the other audio product(s) in your system must support a synchronization mode (word clock, super clock, etc.) that is compatible with Layla. Without such synchronization, the individual pieces of equipment will act independently of each other. This scenario may be fine for some musical applications; however, it is not appropriate for situations where sample-accurate synchronization is required.

For this reason, Layla supports many synchronization modes. Layla can slave to word clock, superclock, S/PDIF, and MIDI Time Code (MTC). In addition, Layla can also generate these synchronization signals, as well as perform translation of one clock to another, such as transmitting super clock while reading MTC.

Let's take a brief look at the various synchronization types.

**Word Clock** – This is a synchronization signal that connects to the BNC connector labeled **Word Clock** on Layla's back panel. This synchronization clock runs at the selected sample rate. Think of it as a kind of electronic metronome, which can click back and forth at speeds surpassing 48,000 times a second. It is one of the most widely used forms of synchronization in digital audio.

**Super clock** – This signal comes from Layla's **Word Clock** connector too. Its signal runs at 256 times the sample rate. A lot of equipment, including Layla, uses a 256x word clock internally. Using super clock allows the equipment to synchronize more accurately and adjust more rapidly to different sample rates.

**Note:** A lot of equipment, including many “clock synchronizers”, generate super clock using a “phase lock loop” or PLL circuit. This can produce a super clock with a lot of “jitter,” which can cause noise on Layla's (and other) analog converters. Layla has a “low-jitter” clock generated using digital synthesis techniques. It is recommended that word clock be used when slaving Layla to other external equipment, reserving super clock for synchronizing multiple Laylas together.

**S/PDIF** – The Sony/Philips Digital Interchange Format is a serial bit-stream that has a clock signal embedded in the data stream. When recording from a S/PDIF source, Layla will utilize the synchronization clock that is embedded in the S/PDIF while it decodes the bitstream.

**Note:** When recording from an S/PDIF port, you must select S/PDIF as the input clock. For greater flexibility, this is not done automatically. If you find that your S/PDIF recordings contain pops or skips, be sure that you have selected S/PDIF as your input clock.

**MIDI Time Code (MTC)** – MIDI time code differs from the preceding synchronization methods. Instead of simply providing the rate at which things should proceed, it transfers information in an elapsed time format (HH:MM:SS.) In addition, MTC also transmits a frame number to give the fine definition that is needed. This longitudinal format has the benefit of

including positional information; however, over time it tends not to maintain as tight a sync as sample based synchronization techniques.

Now let's take a look at some possible configurations and how you might set them up from a synchronization standpoint.

Let's start simple. Suppose that Layla is the only audio device used in your system. Since you have no other devices to synchronize with, simply select "Internal" for Layla's input clock. Layla will then use its own clock to control its operation.

Now a little more complicated set-up: You have two Laylas connected. Simply set Layla #1 to "Internal" for its input clock and superclock for output. Now connect the first Layla to the second one via a BNC cable running from Word Clock Out on Layla #1 to Word Clock In on Layla #2. Now select superclock for Layla #2's input synch. Your Laylas will now operate in unison.

No matter how many devices you are synchronizing, the concept is essentially the same. You are merely "daisy-chaining" devices together using compatible clocks. One device will operate as the source of the master clock, with each successive device using that clock to sync.

## **Contacting Customer Service**

If you experience any trouble with your Layla system please go to the support area of our website at [www.echoaudio.com](http://www.echoaudio.com) and check out the troubleshooting FAQ's we have there. If you can't find a solution to your problem there, please fill out the provided technical support email form. This form will be sent to our technical support staff and they will respond to you quickly. **Please fill out the form completely.** We will not respond to you unless you fill out the form in its entirety. We cannot help you unless you give us the required information.

We do ask you to please read through this manual and the support area of our website before contacting us.

Thank you for buying Layla!

# Appendix A: An Introduction to Digital Recording

## Converting Sound into Numbers

In a digital recording system, sound is represented as a series of numbers, with each number representing the voltage, or amplitude, of a sound wave at a particular moment in time. The numbers are generated by an *analog-to-digital converter*, or ADC, which converts the signal from an analog audio source (such as a guitar or a microphone) connected to its input into numbers. The ADC reads the input signal several thousand times a second, and outputs a number based on the input that is read. This number is called a *sample*. The number of samples taken per second is called the *sample rate*.

On playback, the process happens in reverse: The series of numbers is played back through a *digital-to-analog converter*, or DAC, which converts the numbers back into an analog signal. This signal can then be sent to an amplifier and speakers for listening.

In computers, *binary numbers* are used to store the values that make up the samples. Only two characters, 1 and 0, are used. The value of a character depends on its place in the number, just as in the familiar decimal system. Here are a few binary/decimal equivalents:

<u>BINARY</u>	<u>DECIMAL</u>
0000000000000000	0
0000000000000001	1
0000000000000010	2
0000000000000100	4
0000000000001000	8
1111111111111111	65,535

*Figure A. Binary numbers and their decimal equivalents*

Each digit in the number is called a *bit*, so the numbers in *Figure A* are sixteen bits long, and the maximum value which can be represented is 65,535.

## Sample Size

The more bits that are used to store the sampled value, the more closely it will represent the source signal. In an 8-bit system, there are 256 possible combinations of zeroes and ones, so 256 different analog voltages can be represented. A 16-bit system provides 65,535 possible combinations. A 16-bit signal is capable of providing far greater accuracy than an 8-bit signal. *Figure B* shows how this works.

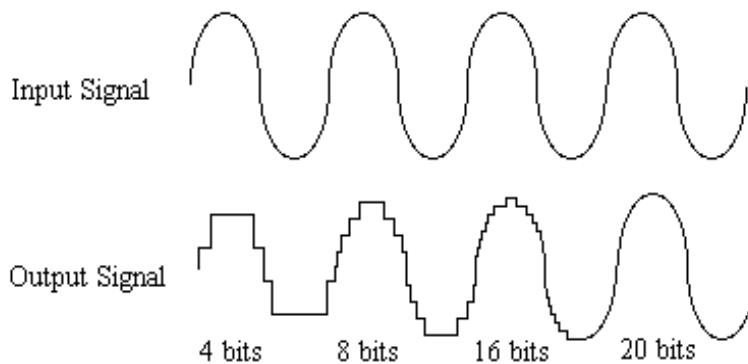

*Figure B. The more bits there are available, the more accurate the representation of the signal and the greater the dynamic range.*

Layla's analog inputs use 20-bit ADCs, which means that the incoming signal can be represented by any of 1,048,576 possible values. The output DACs are also 20-bit; again, 1,048,576 values are possible. The S/PDIF inputs and outputs support signals with up to 24-bit resolution (16,777,216 possible values). Layla processes signals internally with 24-bit resolution to insure that there is no degradation to the audio signal as it is processed through the system.

The number of bits available also determines the potential dynamic range. Moving a binary number one space to the left multiplies the value by two (just as moving a decimal number one space to the left multiplies the value by ten), so each additional bit doubles the maximum value that may be represented. Each available bit provides 6dB of dynamic range. For example, a 20-bit system can theoretically provide 120dB of dynamic range.

## Sample Rate

The rate at which the ADC generates the numbers is equally important in determining the quality of a digital recording. To get a high level of accuracy when sampling, the sample rate must be greater than twice the frequency being sampled. The mathematical statement of this is called the Nyquist Theorem. When dealing with full-bandwidth sound (20Hz–20kHz), you should sample at greater than 40,000 times per second (twice 20kHz). Layla allows you to sample at rates up to 48,000 times per second.

If the sampling rate is lower than the frequency you are trying to record, entire cycles of the waveform will be missed, and the result will not resemble the proper waveform. When the sample rate is too low, the resulting sound has diminished high frequency content.

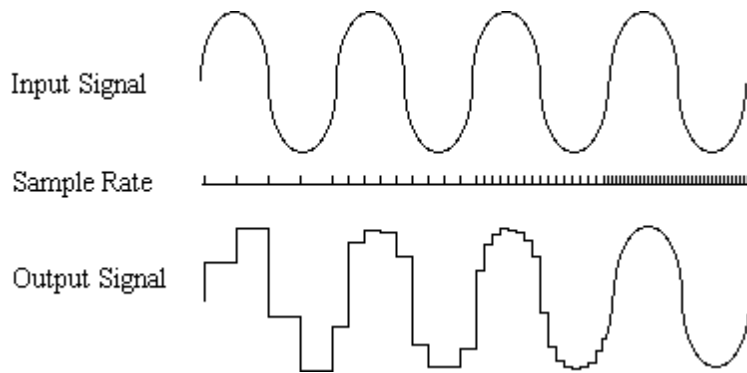

*Figure C. Increased sample rates yield a more accurate reproduction of the source signal.*

By the way, the circuits that generate the sample rate must be exceedingly accurate. Any difference between the sample rate used for recording and the rate used at playback will change the pitch of the recording, just as with an analog tape playing at the wrong speed. Also, any unsteadiness, or jitter, in the sample clock will distort the signal as it is being converted from or to analog form.

## **Storing Digital Data**

Once the waveform has been transformed into digital bits, it must be stored. When sampling in stereo at 48kHz using a 20-bit word size, the system has to accommodate 1,920,000 bits per second. Though this is a lot of data, it is well within the capabilities of personal computers.

Most computer-based digital recording systems record the data directly to the computer's hard disk. Today's hard disks are capable of storing large amounts of data, though the performance of hard drives can vary substantially. The speed and size of your hard drive will be a major determining factor in how many tracks of audio you will be able to simultaneously record and playback.

# Appendix B: Specifications

## Audio Performance

Analog in to analog out

- Frequency Response: 10Hz – 22kHz,  $\pm 0.5$ dB
- Dynamic Range: 98dB
- THD+n:  $< 0.005\%$ , 20Hz–22kHz, A-weighted

## Hardware

- Eight 1/4" TRS balanced analog inputs with precision 20-bit 128x oversampling analog-to-digital converters
- Ten 1/4" TRS balanced analog outputs with high-performance 20-bit 128x oversampling digital-to-analog converters
- Outputs individually switchable between +4dBu and –10dBV
- S/PDIF digital I/O with up to 24-bit resolution
- On-board 24-bit Motorola 56301 DSP (80 MIPS)
- 24-bit data resolution maintained throughout internal signal path
- Word clock/Super clock I/O
- Support for continuous sample rates with single-Hertz resolution

# Index

---

## *A*

adjusting record levels · 33  
analog resolution · 39  
analog-to-digital converter · 38  
ASIO · 22, 25  
ASIO install · 24  
audio connector cable · 6

---

## *B*

boot disk · 8  
breakout box, cable · 6

---

## *C*

checking your Macintosh · 7  
clock, input · 33  
clock, output · 33  
configuring your Macintosh · 8  
console · 23, 28  
console controls · 31  
consumer mode · 31  
consumer output setting · 31  
contents, of box · 6  
customer service · 37

---

## *D*

damping setting · 30  
digital-to-analog converter · 38

---

## *E*

Echo Console · 28  
Echo Console controls · 31  
extensions · 12, 21, 23

---

## *G*

G3 · 6

---

## *H*

hardware installation · 13

---

## *I*

input controls · 31  
input devices · 23  
introduction · 6

---

## *L*

Layla installation · 7

---

## *M*

memory · 7  
memory, virtual · 9  
MIDI · 25  
MIDI time code · 35  
MIDI time code settings · 30  
monitor controls · 32  
mute · 32

---

## *O*

OMS install · 24  
OMS setup · 25  
output devices · 23

---

## *P*

PCI card, installation · 13  
PCI slot · 7

professional mode · 31  
professional output setting · 31

---

**R**

rack-mount box, installing · 14

---

**S**

S/PDIF · 35  
S/PDIF cabling · 15, 17  
S/PDIF output mode · 31  
S/PDIF resolution · 39  
sample rate · 38, 40  
sample size · 39

SCMS copy-protection · 31  
selecting a slot · 13  
software installation · 21  
sound control panel · 9, 10, 11, 23  
static electricity, discharging · 13  
superclock · 35  
synchronization clocks · 33  
synchronizing multiple devices · 34  
system requirements · 6

---

**W**

word clock · 35